

No. 053/2024

5 February 2024

Our Ref: C1/24

**To: All Branches**

Dear Colleagues,

## **Removal of Paper Towels From Royal Mail Group Operational Units Toilets/Washrooms & Replacement Hand Dryer Installation Programme by RMP&FS:**

Following a growing number of complaints from across the country by ASRs and WSRs, the above issue was raised and discussed in detail with the Director RMP&FS and RMP&FS Property Risk and Assurance Lead.

There is a welcome initiative to support the Royal Mail Group's plan to reduce its business environmental impact by removing unnecessary waste to landfill, which includes the phased removal of paper hand towels.

RMP&FS have commenced removing paper hand towels where there are hand driers available. In addition, there is a national programme of engineering works which involves replacing old hand driers with new modern more energy efficient, low noise hand dryers. To date, 280 of RMG's 2,600 sites have had new hand drying machines installed in toilets/washrooms.

Within self-messing areas, where hand washing facilities are not present but there is a requirement to wash and dry crockery and cutlery, Unit PiCs (Persons in Charge) have been informed that they can order and have installed efficient centre feed 'blue' paper towel roll dispensers which can be ordered via the 'Ariba' ordering system.

It has been agreed that going forward, the consultation by RMP&FS Cleaning Managers with site to remove the hand towels and consideration to the number and location of hand dryers and any additional need for the site including centre feed 'blue' paper towel roll dispensers in self-messing facilities where appropriate will be given. Where existing hand driers are in place, but the function is below acceptable standards, a request for replacement will be submitted to update with more efficient, hygienic, low noise type models before removing the paper hand towels.

For hygiene reasons, crockery, cutlery, and food preparation work surfaces should be cleaned and dried with the disposable centre-pull, blue paper roll towels. Shared fabric [tea towels or J-Cloths are not to be used in self-messing facilities as they can](#) harbour bacteria such as E-Coli and Salmonella, viruses and fungal spores which are a source of cross-contamination and infection risks.

### **Centrefeed Dispensers:**

If a Centrefeed dispenser is required, this will need to be ordered via an 'NPI Service Now' request as there will be an installation charge that the Unit will need to request. The exception to the rule is Northern Ireland, N.I. sites need to complete the attached 'Requisition Form' and send it to [asset.fulfilment@royalmail.com](mailto:asset.fulfilment@royalmail.com) – This is due to Bunzl N.I. having a separate catalogue that only delivers in N.I. Only a limited number of people have access to this due to sites ordering from it for delivery to mainland UK!

Centrefeed refill blue paper rolls are on the Authorised Items list and all Unit PiCs will be familiar with ordering them and re-ordering re-fill rolls, listed as follows:

Standard Centrefeed Blue Roll 150M 2 Ply (6 Rolls)	066623	Bunzl
--	--------	-------

Local consultation and engagement with CWU ASRs/WSRs will take place on Local Joint Health and Safety Committee meeting agendas. Any problems can be raised via the RMP&FS Help Desk or with the RMP&FS Cleaning Manager via the Unit PiC.

All enquiries should be directed to the CWU/HQ Health, Safety and Environment Department. Any disagreements should be processed via the RMG/CWU Health and Safety Disputes/Escalations staged process.

**Attachments:**

- Rexel Automatic High Volume Fast Drying Hand Dryer Information Sheet
- "Osily" Heavy Duty High Speed Hand Dryer Information Sheets x 2
- Centrefeed Dispenser and Paper Refill Rolls (Example) image
- Royal Mail Assets Requisition Request Form

Yours sincerely



**Dave Joyce**  
**National Health, Safety & Environment Officer**



NEWLEC

## Hand Dryer Automatic Fast Drying Compact 1.1kw IP x 1 Die-Cast Metal White Enamel

Part Number: 2500964762

MPN: NLBEFD

Product Type: Hand Dryers

EA

Min: 1 EA

### Product Details ▼

Ideal for use in many applications where fast hand drying and energy saving is essential for areas with high traffic volume.

- Infrared touch-free activation
- Blue LED to indicate dry zone
- Compact design - ideal for smaller spaces
- 25000rpm brushed motor
- White powder coated steel cover
- Compact design - ideal for smaller spaces
- Automatically turns off heating element if ambient temperature is above 25°C
- 60m/s airspeed

### Technical Specifications ▼

#### Hand dryer

Housing material	Plastic	Depth	152 mm
Degree of protection (IP rating)	IPX1	Sound level (in operation)	75 dB
Colour	White	Width	180 mm
Type of excitation	Approach electronics	Height	260 mm

Customers who bought this product, also bought



NEWLEC  
[Panel Heater Digital Programmab...](#)

Part Number: 2501091134

- 1 + EA

Min: 1



NEWLEC  
[Panel Heater Digital Programmab...](#)

Part Number: 2501091133

- 1 + EA

Min: 1



NEWLEC  
[Panel Heater Digital Programmab...](#)

Part Number: 2501091132

- 1 + EA

Min: 1

All Osily hand dryers are manufactured to the highest standards. Our products are technologically advanced with a focus on innovation at heart.

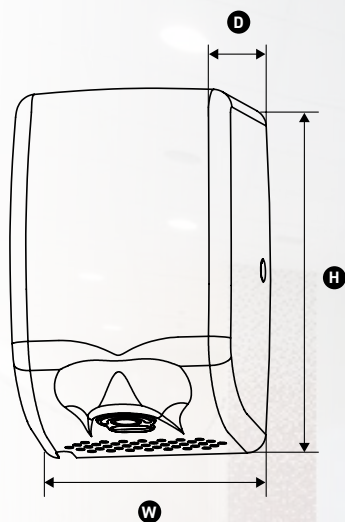

PART NO.	COLOUR	DIMENSIONS (WxHxD)
OSHDCW-M	White	173 x255 x 150mm
OSHDCSS-M	Stainless Steel	173 x255 x 150mm

A high speed hand dryer, ideal for areas with heavy footfall. Featuring an LED airflow light and an anti-bacterial air filter.

### Product Features

- ✓ Microcomputer technology with infrared sensor technology
- ✓ Lab tested in excess of 500,000 times without error.
- ✓ 95% cost saving compared to paper towels
- ✓ ECO friendly, using 80% less energy
- ✓ Anti-bacterial air filter for optimum hygienic solution
- ✓ One piece outer for a high end finish with vandal-proof lock screws
- ✓ Blue LED hot / cold setting

### Technical Data

Voltage:	220-240V, 50/60Hz, 6A, 1350W (Hot) /2.3A, 500W (Cold)
Air Temperature:	40°C (Room Temperature=25°C)
Air Velocity:	100m/s
Air Flow:	140 <sup>3</sup> /H
Drying Time:	8-10 seconds
Sensor Range:	5-15cm
Protection Level:	IPX1
Electric Isolation:	CLASS I
Noise Level (at 1m):	70dB
Material:	Stainless Steel 304
Motor:	Brush Motor, 25000RPM

All Osily hand dryers are manufactured to the highest standards. Our products are technologically advanced with a focus on innovation at heart.

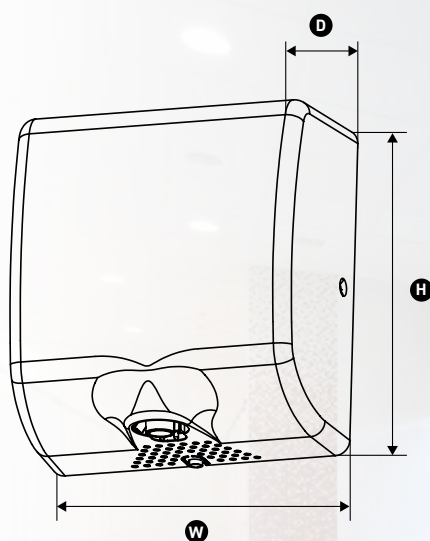

PART NO.	COLOUR	DIMENSIONS (WxHxD)
OSHDCW	White	290 x 320 x 168mm
OSHDCSS	Stainless Steel	290 x 320 x 168mm

A high speed hand dryer, ideal for areas with heavy footfall. Featuring an LED airflow light and an anti-bacterial air filter.

### Product Features

- ✓ Microcomputer technology with infrared sensor technology
- ✓ Lab tested in excess of 500,000 times without error
- ✓ 95% cost saving compared to paper towels
- ✓ ECO friendly, using 80% less energy
- ✓ Anti-bacterial air filter for optimum hygienic solution
- ✓ One piece outer for a high end finish with vandal-proof lock screws
- ✓ Blue LED hot / cold setting

### Technical Data

Voltage:	220-240V, 50/60Hz, 8A, 1800W (Hot) /2.4A, 550W (Cold)
Air Temperature:	40°C (D=10cm, Room Temperature=25°C)
Air Velocity:	100m/s
Air Flow:	140 <sup>3</sup> /H
Drying Time:	8-10 seconds
Sensor Range:	5-15cm
Protection Level:	IPX1
Electric Isolation:	CLASS I
Noise Level (at 1m):	74dB
Material:	Stainless Steel 304
Motor:	Brush Motor, 25000RPM

**Centrefeed Dispenser and Paper Re-fill Rolls  
(Example)**



# Requisition Request Form

## Royal Mail National Asset Team **Requisition Request Form v7**

<b>Requestor Data:</b>			
Date of Request		Job title:	
Request raised by:		Email address:	
Contact phone number:		Contact phone number:	
Contact in Unit (if different):		Other:	
<b>Unit Data:</b>			
Unit name		Unit delivery address:	
Unit opening hours:		Function:	
<b>Budget Data:</b>			
Budget Code/Cost centre (Must be provided).			
<b>Approval/Support (provide as advised)</b>			
Project Lead		ROD or Equivalent	
Finance		SHE Team	
Security Team			

## Works Details

*Provide as much detail as possible and include photos where feasible (use additional Sheet if required)*

Description of the project/request	<i>Overall description of project</i>
What's required	<i>Give as much detail as possible on specifically what is required? If you need item(s) moving/removing from site, please advise if they are the freestanding or fixed? If fixed please supply photos.</i>
Why works are required	<i>Supporting detail on why your request is required? Where possible include any benefits, financial or otherwise</i>
When works need to be delivered	<i>Is there a specific timeline (not just asap)?</i>
Cost	<i>Quotes will normally be sourced once the requests go forward which will include any project management as required. If you have any quotes already or any expectations/understanding around costs / maximum budget, please advise.</i>
Other relevant information	<i>Is there any other relevant information that needs to be considered or factored into the request?</i>

Please send the completed form to your **Asset Team:**



- [asset.fulfilment@royalmail.com](mailto:asset.fulfilment@royalmail.com)

**All faults should be reported to the National Service Centre Helpdesk: 0333 005 0312**